

Perfiles en aluminio

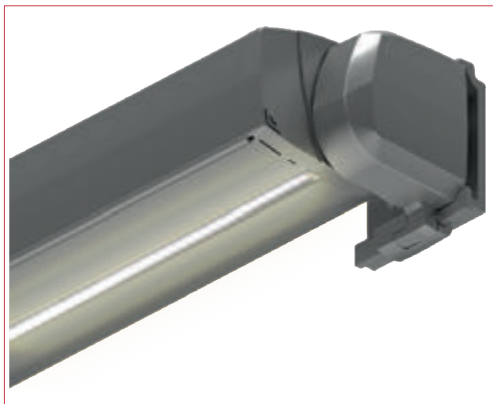

Brazos Arko con cinta Téxtil



Iluminación LED integrada en el perfil cobre (opcional)

CARACTERÍSTICAS

MEDIDAS		
SALIDA	LINEA MINIMA	LINEA MAXIMA
2000	2380	6000
2500	2890	6000
3000	3470	6000
3500	3970	6000
4000	4480	6000

Clase II
Según norma EN13561



ABACO CLASIFICACION AL VIENTO								
3000	3500	4000	4500	5000	5500	6000	L	S
								2000
								2500
								3000
								3500
								4000

49 km/h Clase III 38 km/h Clase II 29 km/h Clase I

INSTALACIÓN

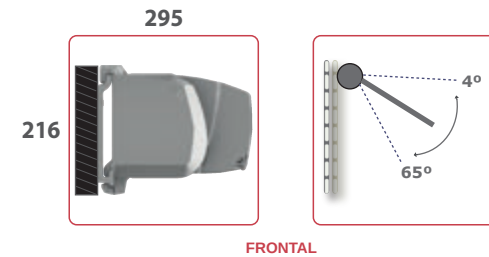

FRONTAL

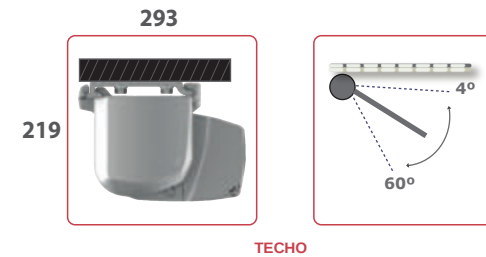

TECHO

ACCIONAMIENTO



MOTOR
(Standard iO)



MOTOR CSI
(Solo inst. Frontal)
OPCIONAL

OPCIONES



LED
(Perfil Cofre)

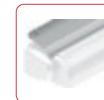

TEJADILLO

CERTIFICACIONES



MARCA CE



TORNILLERIA



LACADO

COLORES BASE



COLORES STANDARD



MÁS INFORMACIÓN
APP

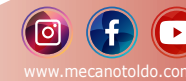

www.mecanotoldo.com