

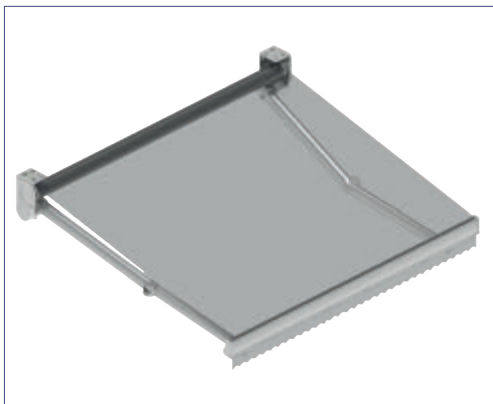

Soportes y perfiles en aluminio



Toldo de dimensiones reducidas



Brazos a doble cable con sistema de tensión interna

CARACTERÍSTICAS

MEDIDAS		
SALIDA	LÍNEA MÍNIMA	LÍNEA MÁXIMA
1000	1230	4500
1250	1480	4500
1500	1730	4500
1750	1980	4500
2000	2310	4500
2250	2560	4500
2500	2820	4500

Clase III
Según norma EN13561



ABACO CLASIFICACION AL VIENTO							
1500	2000	2500	3000	3500	4000	4500	L/s
							1000
							1250
							1500
							1750
							2000
							2250
							2500

49 km/h Clase III 38 km/h Clase II 29 km/h Clase I

INSTALACIÓN

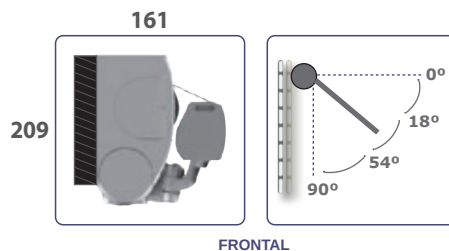

FRONTAL

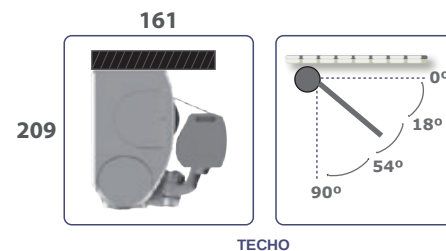

TECHO

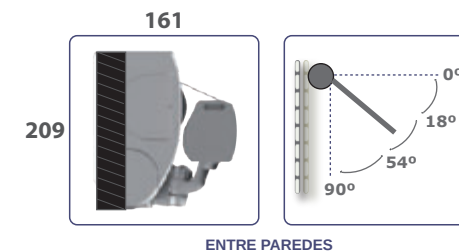

ENTRE PAREDES

ACCIONAMIENTO



MANUAL



MOTOR
(Standard iO)

CERTIFICACIONES



MARCA CE



TORNILLERIA



LACADO

COLORES BASE



Blanco



Ral 1013



Ral 7016



Ral 7016
Texturado



Bronce
Texturado



Negro
Texturado



Ral 8014
Texturado



Plata
Texturado

COLORES STANDARD



Ral 8014



Ral 8017



Ral 8019



Ral 7035



Inox



Ral 7022



Ral 6005



Ral 6009



Ral 3005

MÁS INFORMACIÓN
APP



www.mecanotoldo.com