

Soportes en aluminio

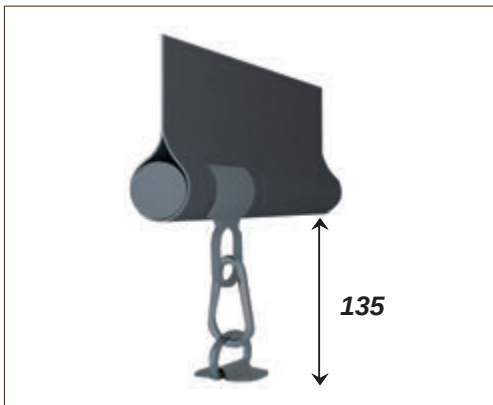

Sistema de fijación toldo 1010



Sistema de fijación toldo 1011

CARACTERÍSTICAS

MEDIDAS		
LINEA MAXIMA	ALTURA MAXIMA	LINEA MINIMA (con motor)
5000	3000	840

Clase II
Según norma EN13561



ABACO CLASIFICACION AL VIENTO						
3000	3500	4000	4500	5000	L	A
						1500
						2000
						2500
						3000

49 km/h Clase III 38 km/h Clase II 29 km/h Clase I

INSTALACIÓN (Modelo 1010)

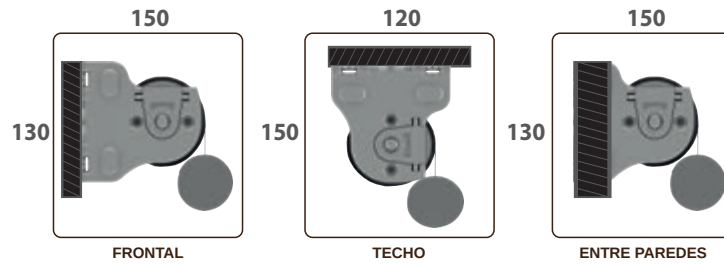

INSTALACIÓN (Modelo 1011)

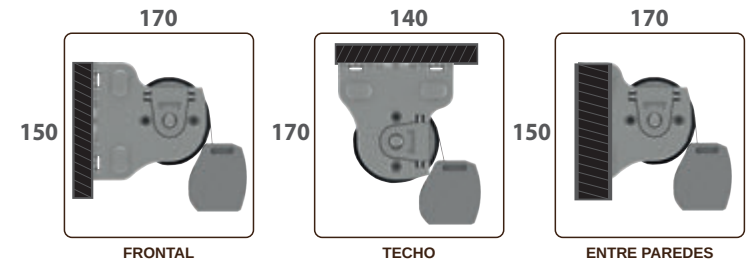

ACCIONAMIENTO



Máquina Estrecha Reforzada

CERTIFICACIONES



COLORES BASE



COLORES STANDARD



MÁS INFORMACIÓN APP



www.mecanotoldo.com