



2026

Store Banne

SMART



Supports en aluminium

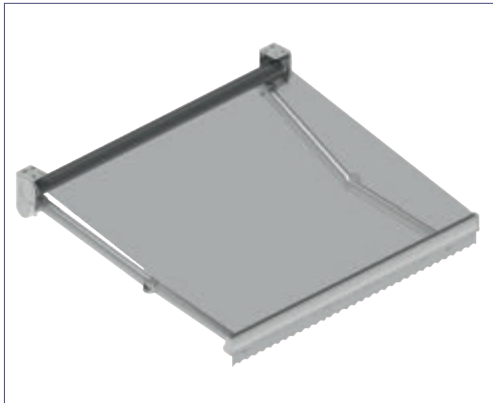

Store de dimensions réduites



Bras Smart avec double câble et tension interne.

CARACTÉRISTIQUES

DIMENSIONS		
AVANCEE	LARGEUR MINIMUM	LARGEUR MAXIMUM
1000	1230	4500
1250	1480	4500
1500	1730	4500
1750	1980	4500
2000	2310	4500
2250	2560	4500
2500	2820	4500

Treuil intérieure ou moteur

Classe III
Selon Norme EN13561



ÉCHELLE CLASSIFICATION AU VENT							
1500	2000	2500	3000	3500	4000	4500	L/A
							1000
							1250
							1500
							1750
							2000
							2250
							2500

49 km/h Classe III 38 km/h Classe II 29 km/h Classe I

INSTALLATION

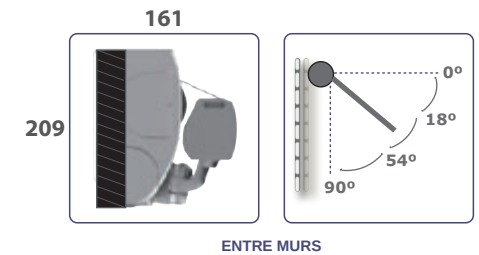
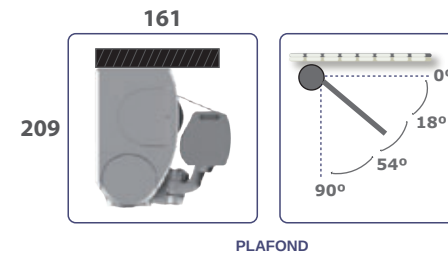
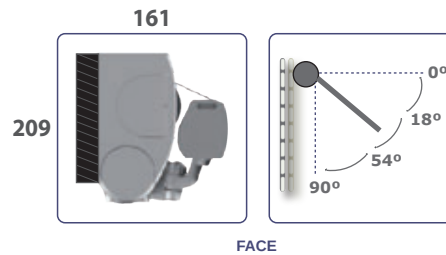

MANŒUVRE



MANUEL



MOTEUR

CERTIFIE



MARQUE CE



VISSERIE



LAQUÉ

COULEURS C-1



Blanc



Ral 1013



Ral 7016



Ral 7016
Texturé



Argent
Texturé



Bronze
Texturé



Noir
Texturé



Ral 8014



Ral 8017



Ral 8019



Ral 7035



Inox



Ral 7022



Ral 6005



Ral 6009



Ral 3005

PLUS D'INFORMATIONS
APP



www.mecanotoldo.com

2026